

David Bell Pulse Circuit Solution

The circuit shows a bell connected to a cell. For the bell to ring, how does the current flow in the circuit?

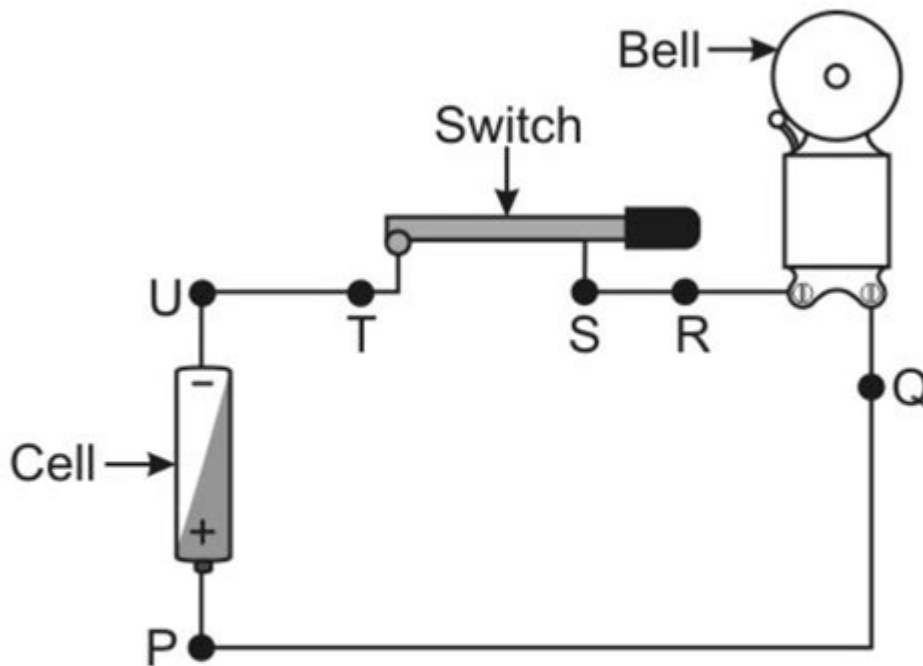

- A. along the path P-Q-R-S-T-U
- B. along the path P-Q-R-S-T-U-P
- C. between points Q-R only
- D. between points P-Q-R and U-T-S only

David Bell pulse circuit solution is a significant topic in the field of electronics and signal processing. The pulse circuit, conceptualized and developed by David Bell, offers innovative approaches for generating and manipulating pulse signals, which are fundamental in various applications, including telecommunications, control systems, and digital circuits. This article delves into the intricacies of David Bell's pulse circuit solution, exploring its design, applications, advantages, and limitations.

Understanding the Basics of Pulse Circuits

What is a Pulse Circuit?

A pulse circuit is an electronic circuit designed to generate, manipulate, or respond to pulse signals. A pulse signal is characterized by its rapid rise and fall times, typically represented as a square wave. These circuits can produce signals that switch between high and low states, making them essential for digital communication, timing applications, and more.

Components of a Pulse Circuit

Pulse circuits generally consist of several key components:

1. Oscillator: Generates the pulse signal.
2. Amplifier: Boosts the signal strength.
3. Timing Elements: Resistors and capacitors that define pulse width and frequency.
4. Transistors: Act as switches to control the signal flow.

The David Bell Pulse Circuit Solution

David Bell's contributions to pulse circuit design have revolutionized the way pulse signals are generated and utilized. His solutions emphasize efficiency, reliability, and versatility.

Key Features of Bell's Pulse Circuit Solution

- High-Frequency Operation: Bell's design allows for high-frequency pulse generation, making it suitable for advanced communication systems.
- Low Power Consumption: The circuit is optimized for minimal energy usage, an essential factor in battery-operated devices.
- Enhanced Signal Integrity: The design minimizes distortion and signal loss, ensuring high fidelity in signal transmission.

Basic Circuit Design

The fundamental design of a David Bell pulse circuit typically involves:

- An Astable Multivibrator Configuration: This configuration allows

continuous pulse generation. The timing components set the frequency and duty cycle of the output pulse.

- Feedback Mechanism: A feedback loop stabilizes the oscillation frequency and ensures consistency in signal generation.
- Output Stage: Often includes a transistor or inverter to drive the load based on the generated pulse.

Applications of David Bell Pulse Circuit Solution

The versatility of David Bell's pulse circuit solution has led to its widespread adoption in various fields. Here are some notable applications:

1. Telecommunications

- Signal Modulation: Bell's pulse circuits are used in modulating signals for efficient transmission over long distances.
- Data Encoding: Employed in encoding schemes such as Pulse Code Modulation (PCM), which is essential in digital communication.

2. Control Systems

- Timing and Synchronization: The circuits are critical in timing applications, ensuring that processes occur in a synchronized manner.
- Automated Control: Used in automated systems where precise control of operations is required.

3. Digital Electronics

- Clock Generation: Pulse circuits serve as clock sources in microcontrollers and digital processors, providing the necessary timing signals.
- Signal Conditioning: The circuits can filter and shape incoming signals for better processing.

Advantages of David Bell's Pulse Circuit Solution

The adoption of Bell's approach offers several advantages:

- **Simplicity:** The design is straightforward, making it accessible for engineers and hobbyists alike.
- **Cost-Effectiveness:** The components used are commonly available and inexpensive, resulting in lower overall project costs.
- **Scalability:** The circuit can be easily modified to accommodate different frequencies and pulse widths for various applications.

Limitations of David Bell's Pulse Circuit Solution

Despite its many advantages, Bell's pulse circuit solution does have some limitations:

- **Limited Pulse Width:** Depending on the components used, there can be constraints on the minimum and maximum pulse widths achievable.
- **Noise Sensitivity:** The circuits may be susceptible to noise, which can affect signal integrity, especially in high-frequency applications.
- **Thermal Stability:** High-power applications could lead to thermal issues, requiring additional considerations in design.

Implementing a David Bell Pulse Circuit

Building a David Bell pulse circuit can be an excellent project for electronics enthusiasts. Here is a step-by-step guide to implementing a basic version:

Required Components

- 2 x NPN Transistors
- Resistors (values dependent on desired frequency)
- Capacitors
- Power Supply (typically 5V DC)
- Breadboard and Jumper Wires

Step-by-Step Instructions

1. Set Up the Oscillator:

- Connect two NPN transistors in a feedback configuration to create an astable multivibrator.
- Use resistors to set the timing characteristics.

2. Define Pulse Width and Frequency:

- Choose resistor and capacitor values to determine the pulse frequency and width according to the formula:

$$f = \frac{1.44}{(R1 + 2R2)C}$$

- Adjust these values to achieve the desired results.

3. Connect the Output:

- Use an output transistor to drive a load or connect the output to an oscilloscope to visualize the pulse signal.

4. Testing and Calibration:

- Power the circuit and observe the outputs. Adjust the resistor values as necessary to achieve stable operation.

Conclusion

The David Bell pulse circuit solution stands as a testament to innovative design in electronics, providing a robust and versatile approach to pulse signal generation. Its simplicity and efficiency make it a valuable tool in various applications ranging from telecommunications to digital electronics. While it does have some limitations, the advantages it offers ensure its continued relevance in the ever-evolving landscape of electronics. By understanding its principles and applications, engineers and hobbyists can effectively utilize Bell's pulse circuit solutions in their projects, paving the way for advancements in technology and communication.

Frequently Asked Questions

What is the David Bell pulse circuit solution?

The David Bell pulse circuit solution refers to a specific configuration of electronic circuits designed to generate and manipulate pulse signals for various applications in electronics and communications.

What are the key components used in the David Bell pulse circuit?

Key components typically include resistors, capacitors, transistors, and operational amplifiers, which work together to shape and control the pulse output.

How does the David Bell pulse circuit improve signal

integrity?

The circuit is designed to minimize signal distortion and noise, ensuring cleaner pulse signals that are crucial for high-speed data transmission and accurate timing in digital systems.

What applications can benefit from the David Bell pulse circuit solution?

Applications include telecommunications, pulse width modulation, digital signal processing, and various timing circuits in embedded systems.

Can the David Bell pulse circuit be simulated using software?

Yes, the circuit can be effectively simulated using software tools like SPICE, which allows engineers to analyze the circuit behavior before physical implementation.

What are common challenges when designing a David Bell pulse circuit?

Common challenges include managing component tolerances, ensuring stability under varying loads, and minimizing electromagnetic interference (EMI) in the designed pulse signals.

Is the David Bell pulse circuit suitable for low-power applications?

Yes, with careful design considerations, the David Bell pulse circuit can be optimized for low-power applications, making it suitable for battery-operated devices and energy-efficient systems.

Where can I find resources to learn more about the David Bell pulse circuit solution?

Resources can be found in electronics textbooks, online courses focused on circuit design, and technical papers published in journals related to electronics and communication engineering.

Find other PDF article:

<https://soc.up.edu.ph/64-frame/pdf?trackid=daG85-5709&title=vectors-and-projectiles-worksheet-answers.pdf>

David Bell Pulse Circuit Solution

David Bell - Pulse
Circuit Solution

Fundamental of power electronics ...

David Middlebrook 2023 IEEE William E. Newell Fundamentals of Power Electronics

David Yang ...

David Yang tenure HK tenure

David Tong -

(first name), (last name). first name last name

DAVID ...

20 DAVID DAVID

David Tong -

David Tong -- Theoretical Physicist at the University of Cambridge

David Tong -

Part III Symmetries, Fields, and Particles

David Bowie -

Jan 11, 2016 · David 1985 Mick Jagger Mick Dancing in the Street MV Youtube "I've watched gay porn and felt ...

David Evans -

May 1, 2022 · David A. Evans Evans

Chaussures Pieds nus Leguano - David Manise

Sep 21, 2013 · Salut, j'ai vu et essayé en magasin les chaussures pieds- nus leguano. Ca me dit plus que ceux avec les orteils séparés. Vachement confortable, mais je sais pas quoi penser ...

David Bell - Pulse
Circuit Solution

Fundamental of power electronics ...

David Middlebrook 2023 IEEE William E. Newell Fundamentals of Power Electronics

David Yang

David Yang tenure HK tenure

David Bell ...

David Bell - Theoretical Physicist at the University of Cambridge

David Bell (first name) Bell, David (last name). David Bell first name David last name Bell ...

David Bell DAVID Bell ...

David Bell 2010 DAVID Bell David Bell DAVID Bell Evans ...

David Tong - Theoretical Physicist at the University of Cambridge

David Tong -- Theoretical Physicist at the University of Cambridge

David Tong - Theoretical Physicist at the University of Cambridge

David Tong Part III Symmetries, Fields, and Particles ...

David Bowie - Singer

Jan 11, 2016 · David 1985 Mick Jagger Mick Dancing in the Street MV Youtube "I've watched gay porn and felt ..."

David Evans - Theoretical Physicist at the University of Cambridge

May 1, 2022 · David A. Evans Evans ...

Chaussures Pieds nus Leguano - David Manise

Sep 21, 2013 · Salut, j'ai vu et essayé en magasin les chaussures pieds- nus leguano. Ca me dit plus que ceux avec les orteils séparés. Vachement confortable, mais je sais pas quoi penser ...

Explore the David Bell Pulse Circuit solution to optimize your circuits efficiently. Discover how this innovative approach can enhance your projects. Learn more!

[Back to Home](#)